

Installation instructions
Wall flashing profiles

WA 150
WA 1 - ÜK 150 - 275
WA 1 - Ü 150 E

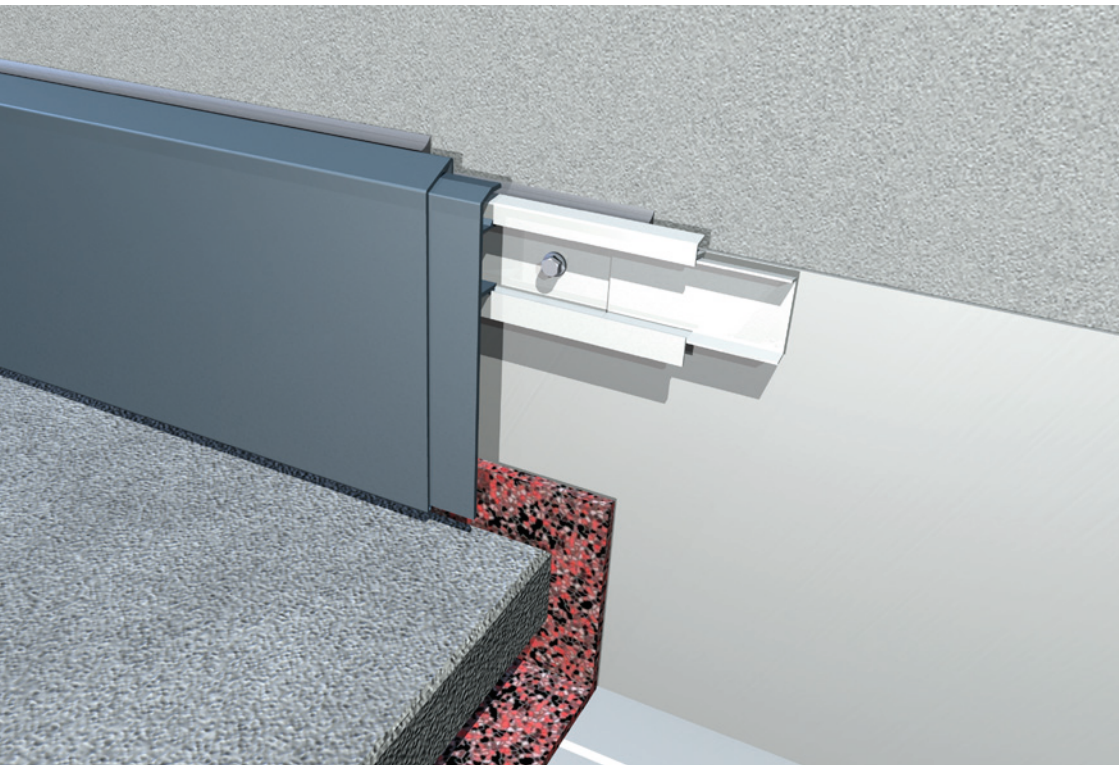

Installation basics

Profiles and preformed details are to be checked upon receipt, noticeable transport damages are to be reported immediately or stated on the consignment note upon receipt.

Aluminium profiles must be stored in a weather-protected place. Dry storage is especially required to prevent irreparable corrosion damage of visible mill and plate finish surfaces. If the packaging has become moist, the material needs to be dried or processed the same day. For drying, keep the profiles separately to ensure sufficient air circulation.

During installation, make sure not to damage the visible profile surfaces. Aluminium profiles must be protected against adverse impacts of both other metals and acids and alkaline substances (e.g. cement plaster, chalk).

Natural aluminium

When working with mill-finished profiles it is recommended to wear gloves to avoid fingerprints on the visible surface while handling.

As regards preformed details and corners made of natural aluminium (without secondary surface treatment), handling marks cannot be completely excluded and are not considered defects.

Remove the protective film (if any) from profiles directly after installation!

After installation of the profiles, natural aluminium will generate a protective oxide coating. This greyish patina with different patterns does not always meet aesthetic requirements.

Installation basics

The colour coating provides the aluminium profiles with a permanently decorative smooth surface.

Colour-coated and surface-treated products

If colour-coated profiles need to be cut to size on site, first **carefully mask** the surface in order to avoid scratches, then use e.g. a jigsaw, circular saw (saw blade for NF metals) or angle grinder (! **thin !** cut-off wheel approx. 1 mm for **thin-gauge** NF metals < 3 mm). Please note that excessive heat impact may damage the colour coating! Subsequently deburr the raw edge using a flat fine file and coat with supplied lacquer (brush or piece of fleece fabric).

With anodised surfaces and special effect coating (metallic, pearlescent finish), visually noticeable irregularities cannot be excluded.

Fasteners and substrate

Generally, delivery does not include any fastening materials. Suitable fastening materials (screws / plugs / washers) are to be selected according to the substrate. Responsibility lies with the installer.

The installer or the site manager is responsible for checking the load-bearing capacity of the substrate.

Joint width

When installing aluminium edge trim profiles, wall capping profiles and wall flashing profiles, possible temperature-induced changes of the profile length must be considered; connections and fixings must be carried out so as to allow the details to expand, to contract or to shift as the temperature changes, without causing any damage. In this case, a temperature difference of 100 K — at a range of -20 °C to +80 °C — shall be assumed.

Joint width between alwitra edge trim profiles or top caps as well as wall flashing profiles depending on the profile temperature at the time of installation:

Profile temperature at the time of installation	+5 °C	+10 °C	+20 °C	+30 °C
Minimum joint width per linear metre of profile length ¹	1.8 mm/lin. m	1.6 mm/lin. m	1.4 mm/lin. m	1.2 mm/lin. m
Recommended joint width at 5.00 m profile length	9 mm	8 mm	7 mm	6 mm
Recommended joint width at 2.50 m profile length	4.5 mm	4 mm	3.5 mm	3 mm

Table 1: Joint width depending on profile length and installation temperature

¹ based on linear thermal expansion $\alpha = 23.8 \cdot 10^{-6} [1/^\circ\text{C}]$

Installation plans

Installation plans will be drawn up for the client / installer by the alwitra Technical Department following a quantity survey for ordering profiles. Material requirements will be determined and optimised in the process of plan development, fixing bracket centres will be indicated in accordance with the individual object.

Installation plans may include the following information:

- positioning and distribution of profile sections,
- execution and positioning of corners, preformed details and end sections,
- layout of fixing brackets / joint connections,
- profile cross-sections including description,
- the specified material requirements,
- information on the surface as well as further notes on fabrication and installation.

Drawing up of installation plans is a free-of-charge service from alwitra. However, control responsibility lies with the client / installer. In case of any queries, the consecutive plan number in the text field provides for unmistakable identification. A weatherproof installation plan for the site will be included in the delivery.

In general, profile sections will be supplied in corresponding standard lengths. They are to be installed on site according to the installation plan. Standard length profile sections, which need to be cut to length on site, will be marked with an additional part number separated by a dot, e. g. 2.1, 2.2, following the section number ...

In the example, the 5.00 m standard length profiles pos. ① and pos. ③ are installed as full-length sections, whereas the profiles pos. ②.1 and ②.2 must be cut to length from a standard length profile pos. ② and then installed.

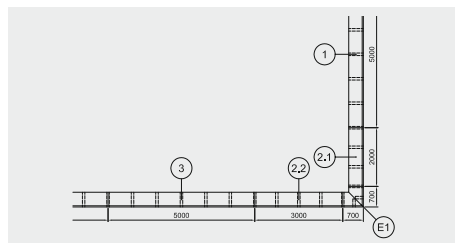

Wall flashing profile WA 1 - ÜK / WA 1 - Ü 150 E

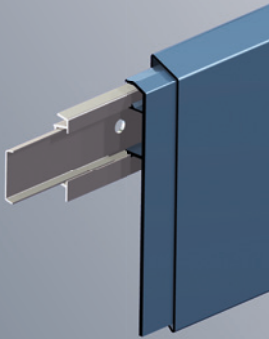

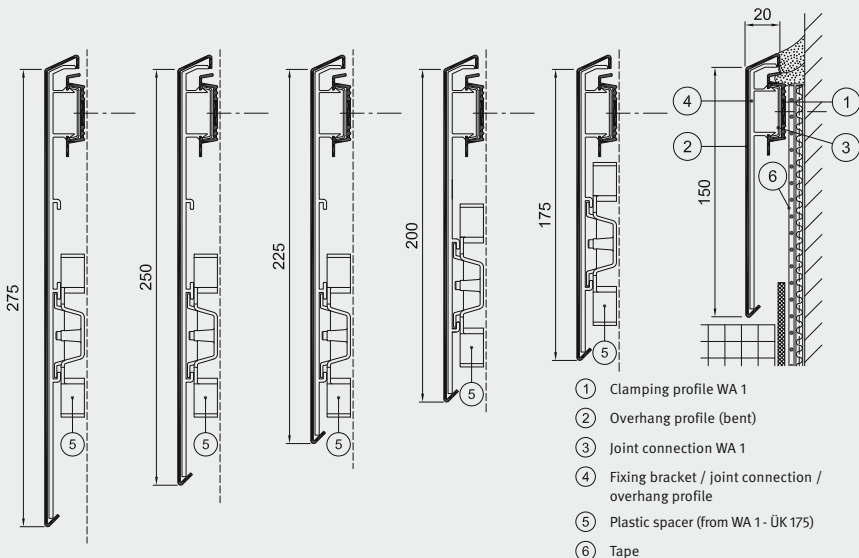

- extruded rigid aluminium clamping profile, EN AW-6060 T66, with folded aluminium overhang profile, EN AW-5005A
- corrosion resistant, recyclable
- 3.00 m long clamping profile sections with joining plates, punched holes 6.5 x 8 mm, centre = 192 mm
- 3.00 m long overhang profile sections with a front height of 150, 175, 200, 225, 250 and 275 mm, which are snapped onto the fixing brackets / joint connections (from 175 mm with additional plastic spacer) inserted into the clamping profile
- invisible screw connection
- ready-to-install right-angled internal and external corners, special corners and end caps
- with colour coating or anodised, if required

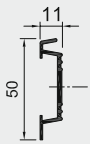
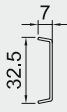

Wall flashing profiles for used roof areas

Scope of delivery:

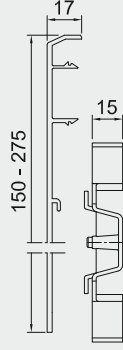
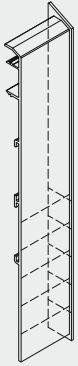
	Clamping profile	Joint connection (installation aid)	Overhang profile	Fixing bracket – joint connection	Stop ends
WA 1 - ÜK 150 - 275	 <p>section length 3.00 m, corner leg length 19/19 cm, pre-punched holes 6.5 x 8 mm, distance 192 mm</p>	 <p>1 joint connection / section and 2 / corner</p>	 <p>profile section length 3.00 m, corner leg length 22.5/22.5 cm</p>	 <p>3 fixing bracket – joint connections / section distance 1.00 m 2 fixing bracket – joint connection / corner 1 plastic spacer / fixing bracket – joint connection (from 175)</p>	 <p>Stop ends RH (Stop ends LH)</p>

Fixing bracket layout
WA 1 - ÜK 150 - 275

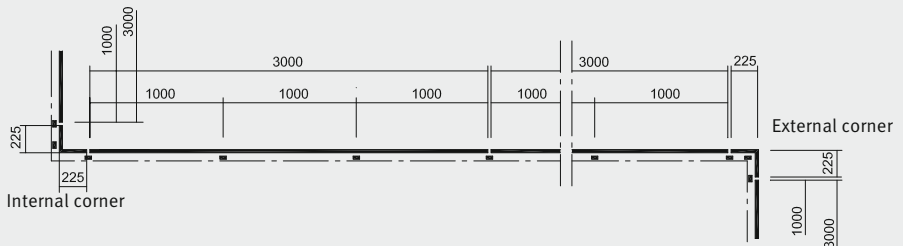

Installation instructions WA 1 - ÜK / WA 1 - Ü 150 E

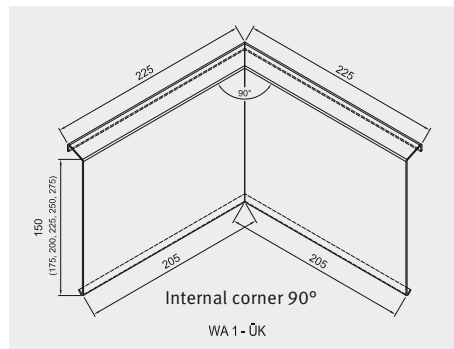
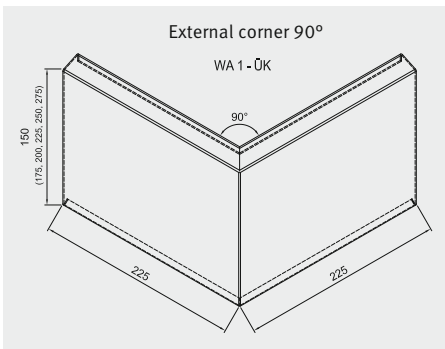
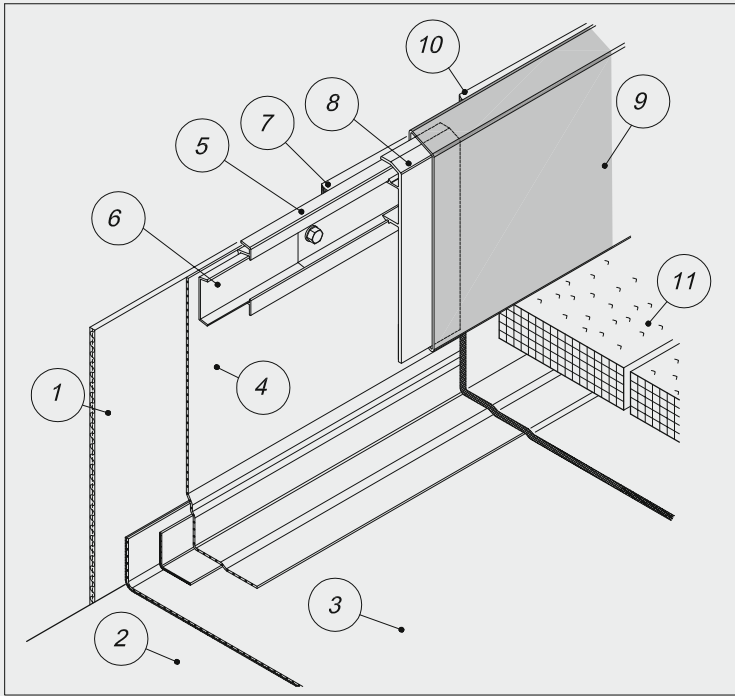

An installation video on wall capping profiles is available at www.alwitra.de/en/videos-english/ or scan the QR code.



Installation instructions WA 1 - ÜK / WA 1 - Ü 150 E

Installation sequence

After installing the

- ① vapour barrier
- ② thermal insulation and
- ③ waterproofing, perimeter fastening
incl. ④ tape
- ⑤ fix the clamping profile on the ④ tape
in the rising constructional element
using corrosion-resistant screws and
plugs at centres $e = 192 \text{ mm}$, starting
from the corners.
- ⑥ Prior to installing the next profile
section, insert the joint connection from
the side into the clamping profile end
(installation aid).
- ⑦ Seal the joint between the clamping
profile and the rising constructional
element with joint sealant.

- ⑧ Fixing bracket – joint connection for the
overhang profile must be snapped into the
clamping profile at ⑤ centres of 1.00 m
(from WA 1 - ÜK 175 with plastic spacer).
- ⑨ Overhang profile, starting from the
corners, to be installed as follows:
 - a fixing bracket – joint connection is
snapped onto the clamping profile at
one side of the corner, one leg of the
corner is snapped onto this fixing
bracket – joint connection
 - a second fixing bracket – joint connec-
tion is snapped onto the clamping pro-
file at the other side of the corner next
to the corner leg, the fixing bracket – joint
connection plate is inserted from the
side into the nonsupported corner leg
 - further fixing brackets – joint connec-
tions for the overhang profile are
snapped onto the clamping profile, the
overhang profile is snapped onto the
fixing brackets – joint connections
- ⑩ Seal the joint between the overhang
profile and the rising constructional
element with joint sealant.
- ⑪ Apply protection layer, paving slabs,
concrete screed or gravel.

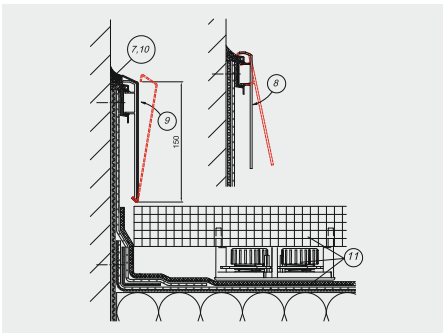

Wall flashing profile WA 1 - Ü 150 E

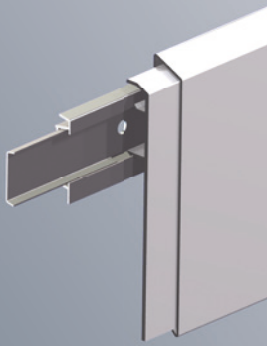

- extruded rigid aluminium clamping profile with extruded aluminium overhang profile, EN AW-6060 T66
- corrosion resistant, recyclable
- 3.00 m long clamping profile sections with joining plates, punched holes 6.5 x 8 mm, centre = 192 mm
- 3.00 m long overhang profile sections with a front height of 150 mm, anodised E6/EV1 and with protective film, which are snapped onto the fixing brackets / joint connections inserted into the clamping profile
- semi-gloss anodised overhang profile with increased scratch resistance and enhanced corrosion resistance for a lasting decorative surface
- invisible screw connection
- ready-to-install right-angled internal and external corners, special corners and end caps

- ① Clamping profile WA 1
- ② Overhang profile (anodised E6/EV1)
- ③ Joint connection WA 1
- ④ Fixing bracket / joint connection / overhang profile
- ⑤ Tape

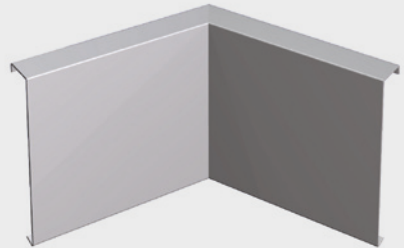
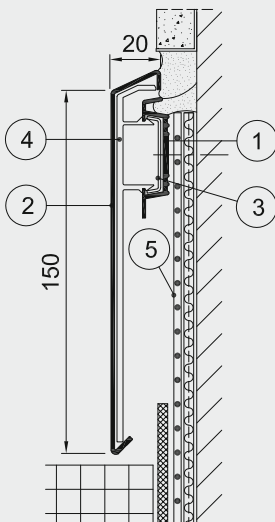

ready-to-install right-angled internal corner



WA 150 - Ü 150 E external corner

Wall flashing profile WA 150

- extruded multi-piece aluminium clamping profile, 150 mm high, EN AW-6060 T66
- rigid and noncorrosive, recyclable
- 3.00 m long clamping profile sections with joint connections, punched holes \varnothing 8.5 mm, centre = 192 mm
- visible screw connection
- ready-to-install right-angled internal and external corners, special corners and end caps
- with colour coating or anodised, if required

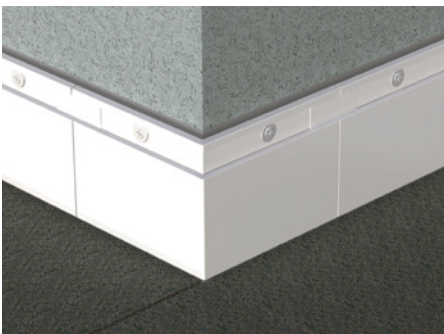
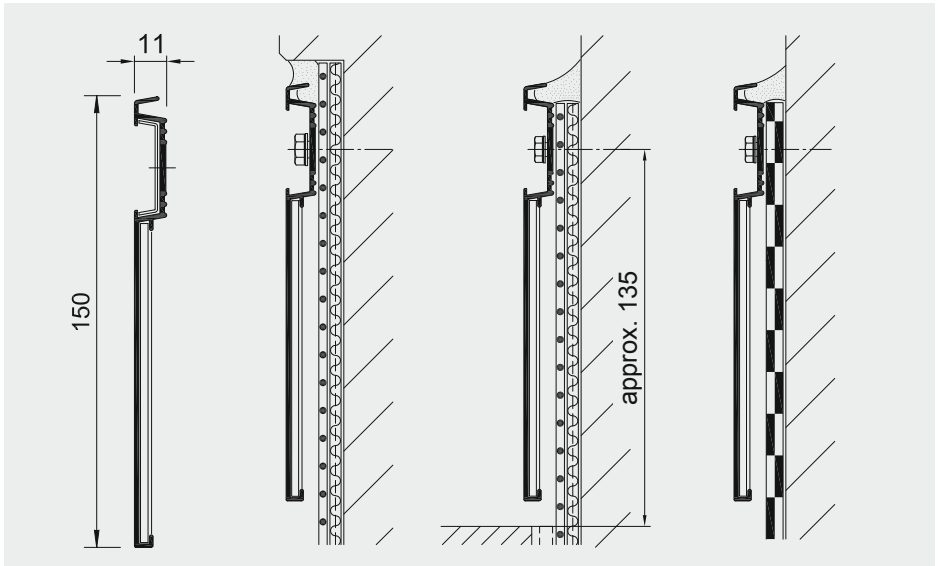

WA 150 external corner

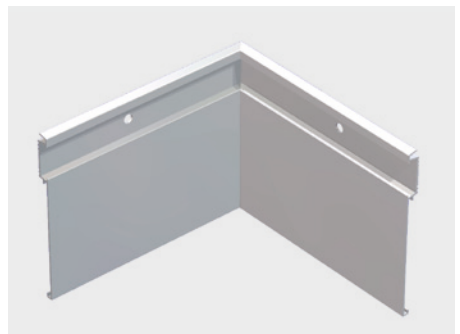

WA 150 internal corner



alwitra GmbH & Co.
54229 Trier · Germany
Phone: +49 651 9102-0
Fax: +49 651 9102-248
export@alwitra.de · www.alwitra.de